

R760, R762/R790, R791/R796, R797/R798 for 1String

R753, R755, R756/R780/R792, R793/R794, R795/C765/C771/C766 for 2String

Vovp: 3V
Difference between OVP1 and OVP2 Protection Threshold: 0.6V

OVP=120V

OVP=120V

VIS=0.5V

					<拟制>	
					<审核>	
标记	数量	更改单号	签名	日期	2018.04.11	
						第 张

OZ9976A

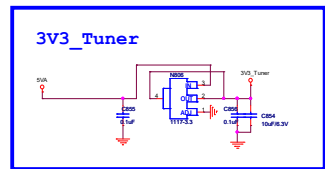
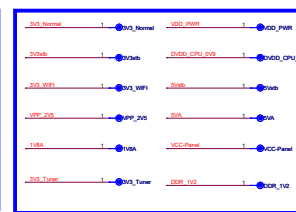
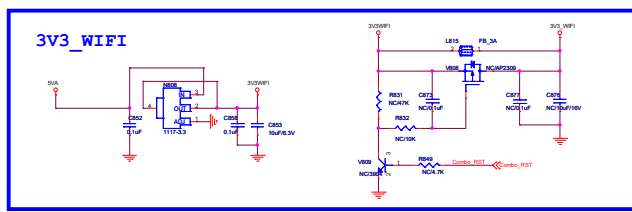
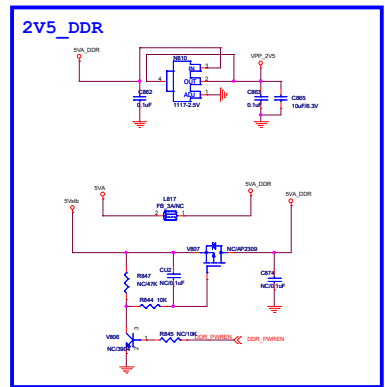
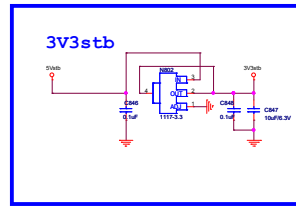
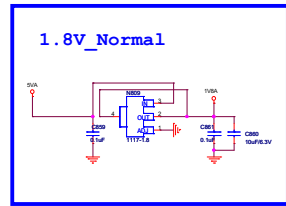
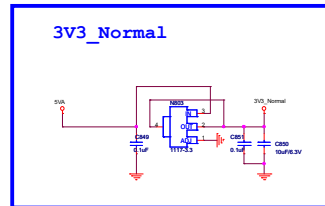
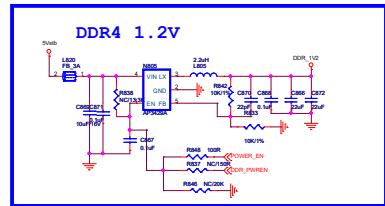
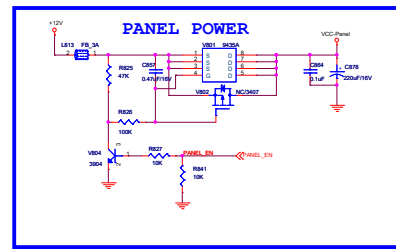
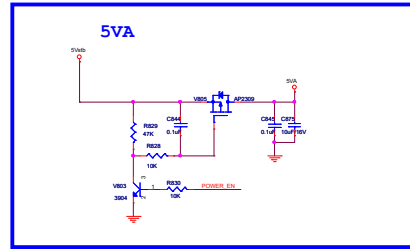
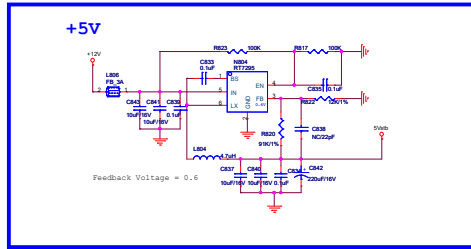
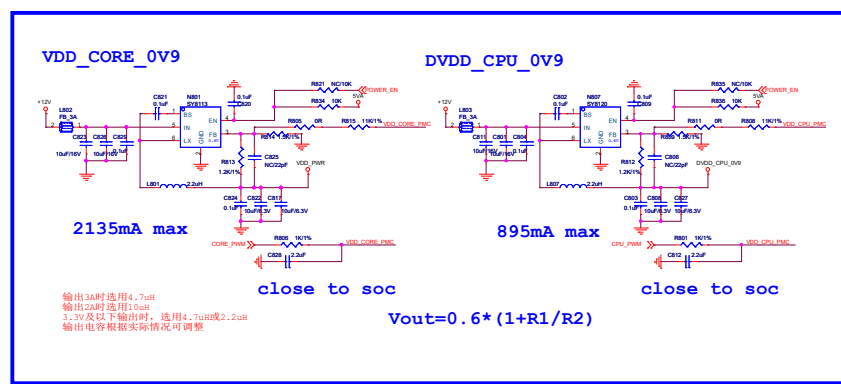
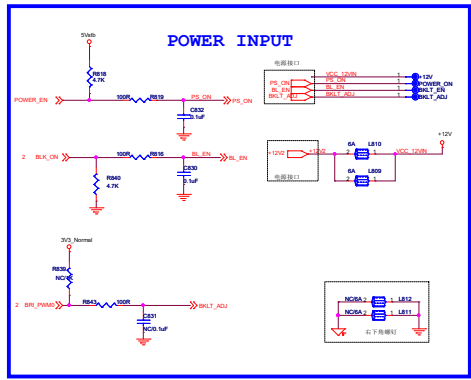

Unit 1 of Hi3751V551(POWER)

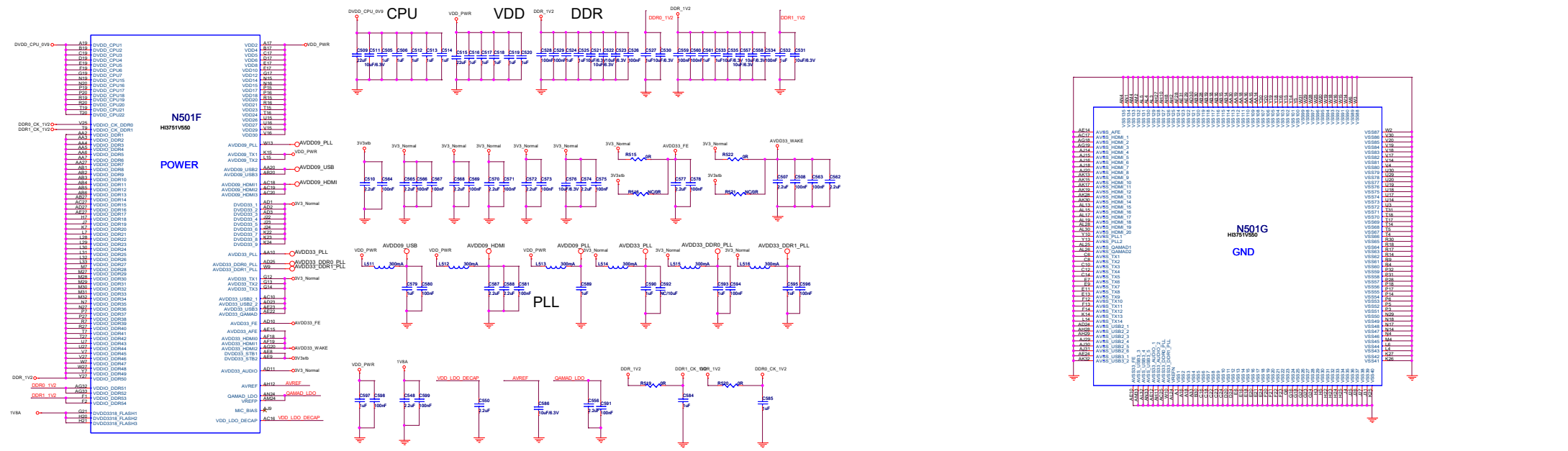

				控制
				审核
				02_V551 POWER Interface
标记	数量	更改单号	签名	日期

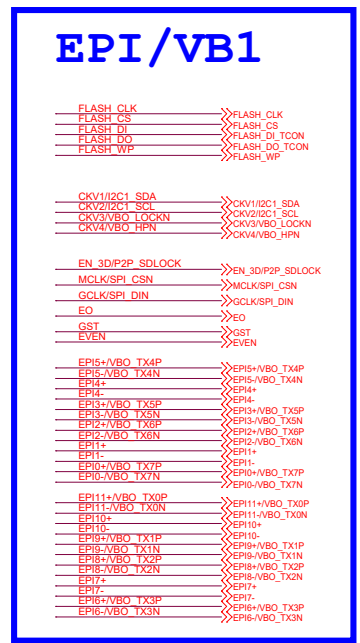
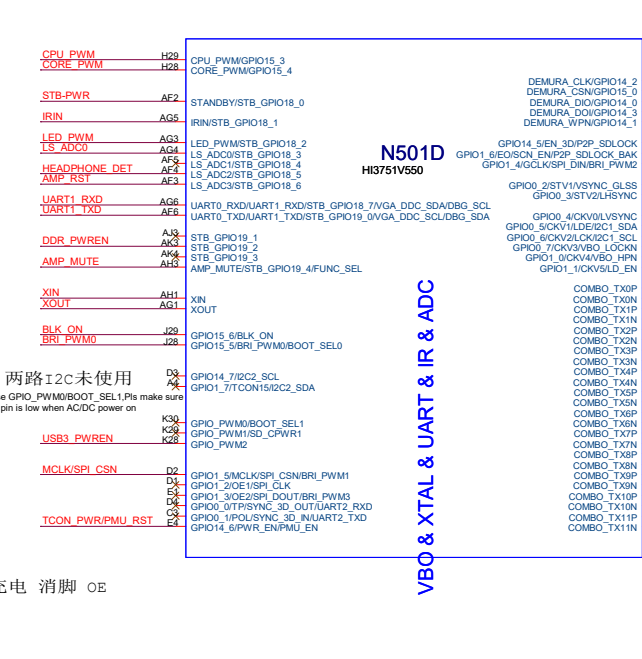
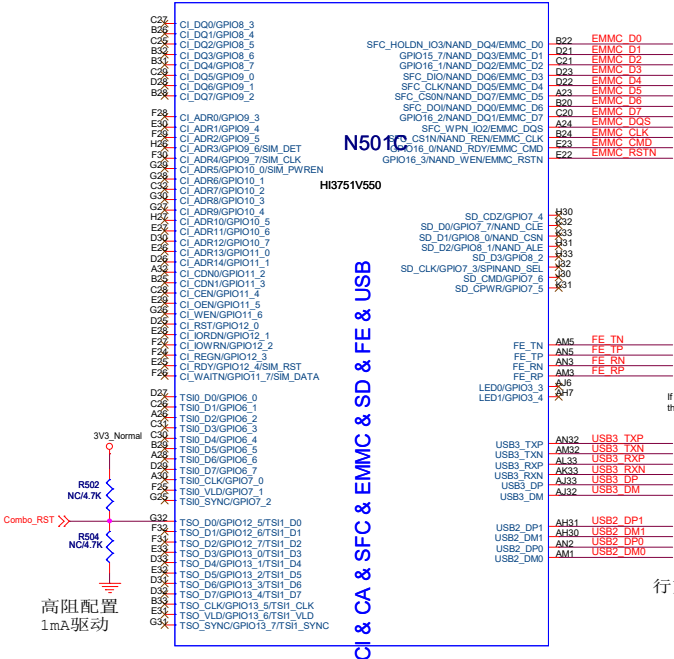

EMMC HS400

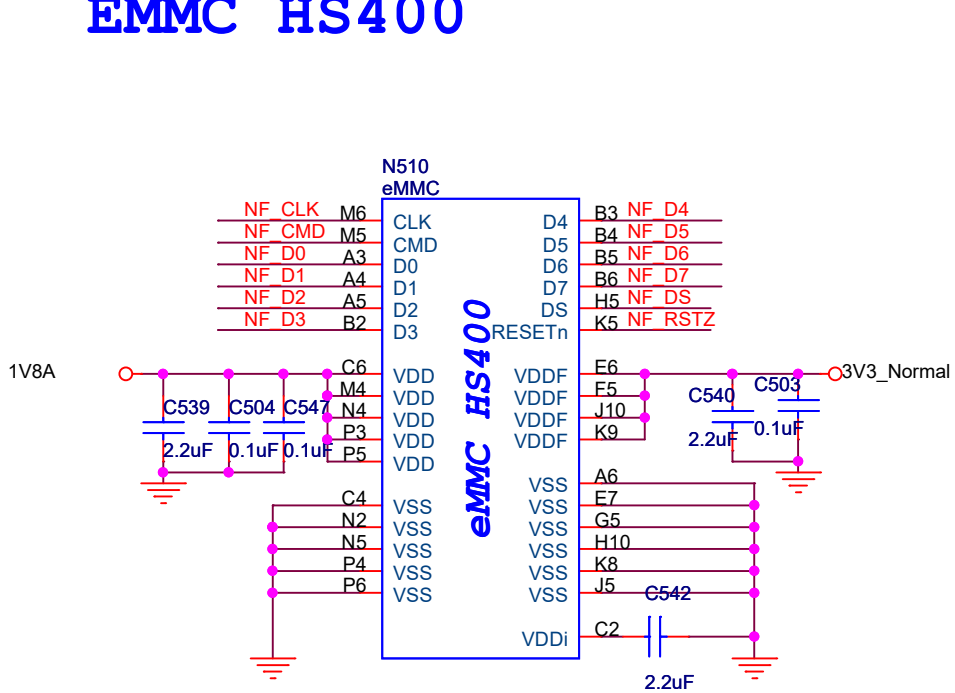

如果使用三星EMMC，
需要将data0~data7、
CMD的串联33ohm电阻
改为0ohm

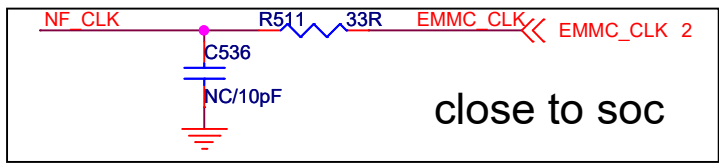
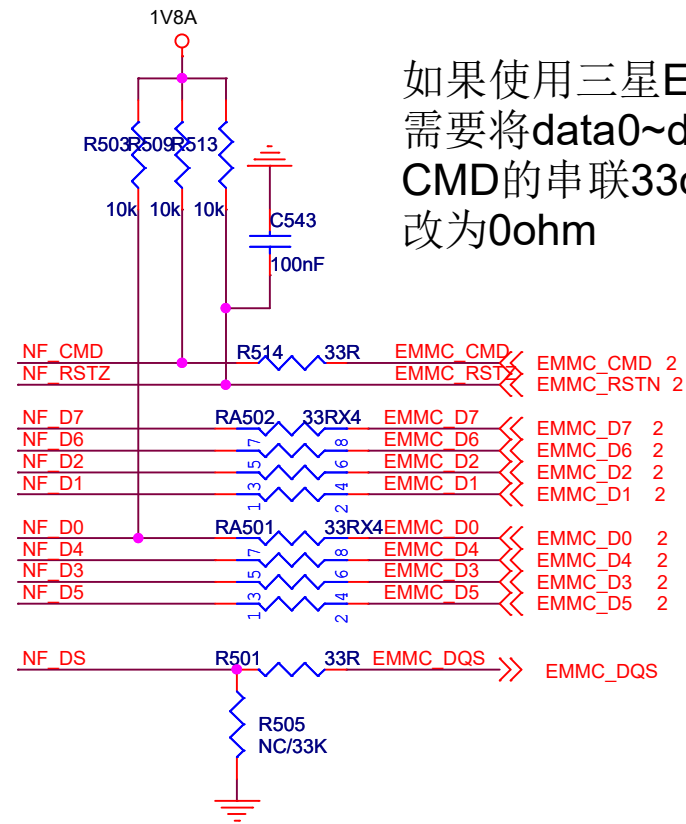

					拟制		06. EMMC HS400
					审核		
标记	数量	更改单号	签名	日期			
							第 6 张

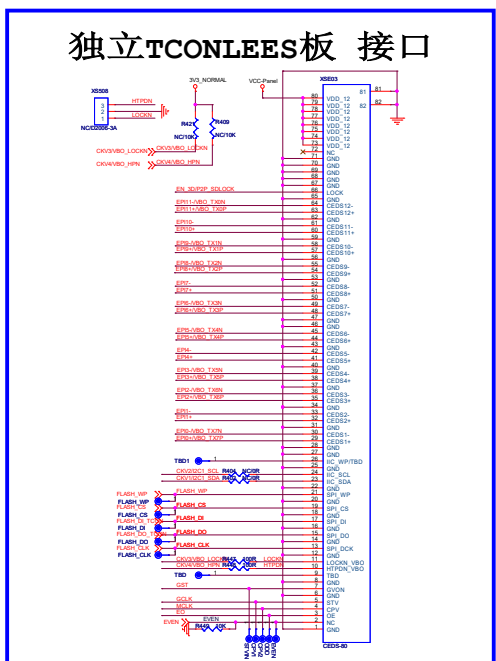
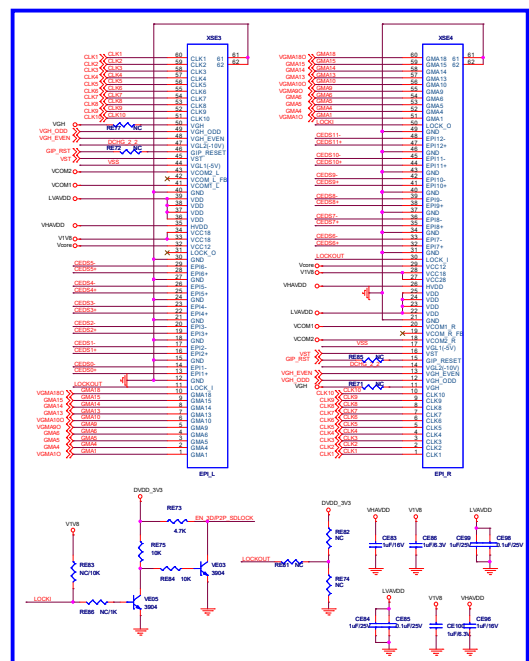
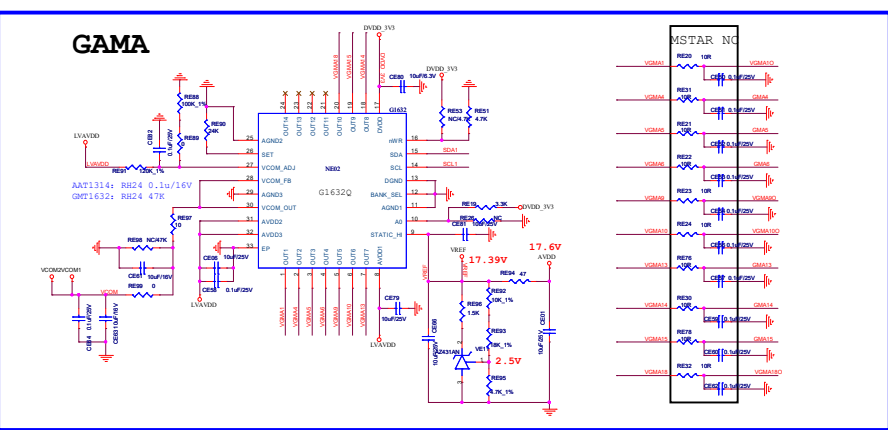
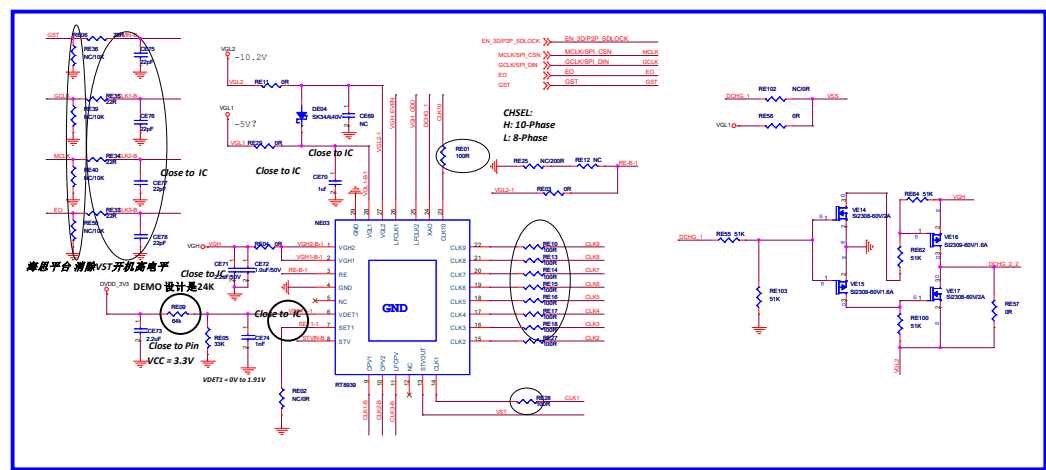
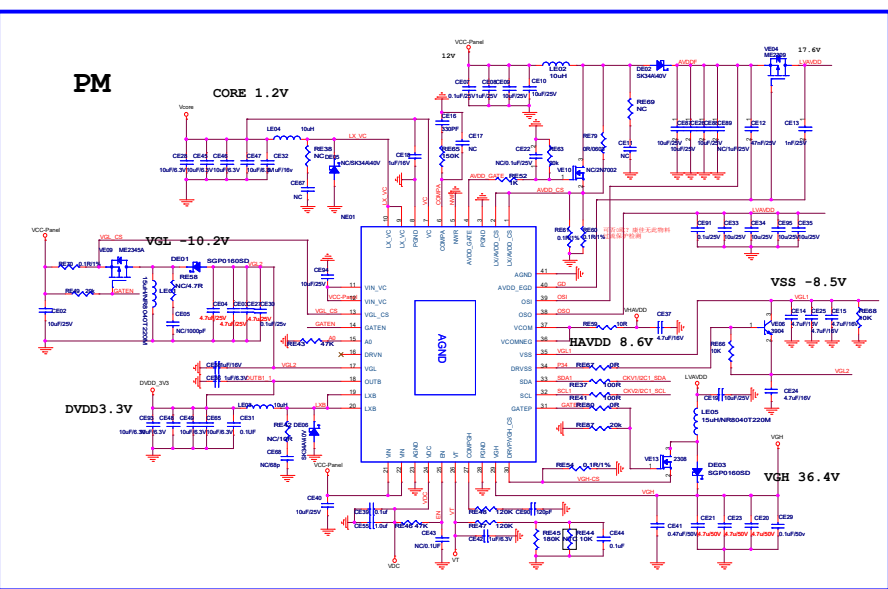

测试点

VGH	1	36.4V	100mA
VGL2	1	-10.2V	200mA
VVDD	1	8.6V	200mA
VVSS	1	-8.5V	200mA
DVDD	1	3.3V	200mA
VCC1.2V	1	1.2V	200mA
VCC1.8V	1	1.8V	200mA
VCC1.5V	1	1.5V	200mA
VCC1.0V	1	1.0V	200mA
VCC0.9V	1	0.9V	200mA
VCC0.8V	1	0.8V	200mA
VCC0.7V	1	0.7V	200mA
VCC0.6V	1	0.6V	200mA
VCC0.5V	1	0.5V	200mA
VCC0.4V	1	0.4V	200mA
VCC0.3V	1	0.3V	200mA
VCC0.2V	1	0.2V	200mA
VCC0.1V	1	0.1V	200mA

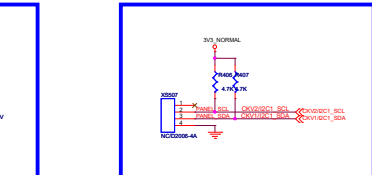
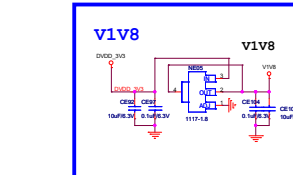

电气类别	EPI	电压	电流	CEDS	电压	电流
VGH	RE107	OR	NC			
VGL2	RE103	OR	NC			
VVDD	VCOMLFB	RE113	OR	NC		
VVSS	LOCKOUT	RE115	OR	NC		
DVDD	VCOM	RE116	NC	OR		
VCC1.2V	VCOM1	RE102	OR	NC		
VCC1.8V	VCOM2	RE112	OR	NC		
VCC1.5V	VGH	RE101	OR	NC		
VCC1.0V	VCOM1	VCOM1/VCOM2	EPI分开调			
VCC0.9V	VCOM2	VCOM1/VCOM2	EPI分开调			
VCC0.8V						
VCC0.7V						
VCC0.6V						
VCC0.5V						
VCC0.4V						
VCC0.3V						
VCC0.2V						
VCC0.1V						

备注: 电气参数可调, 时序可调整
难点在于VGL1电路不太兼容,
L/S兼容性待确认, 涉及芯片选型

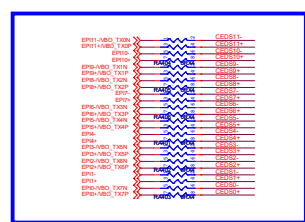

AV

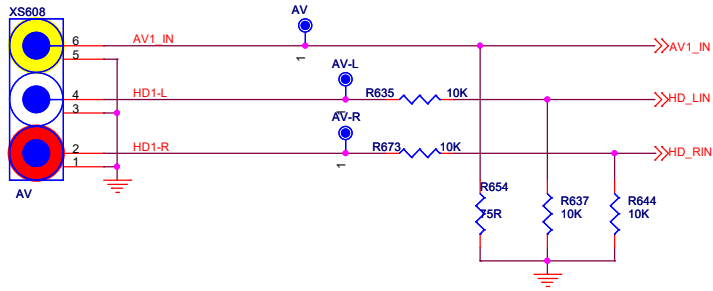

SPDIF

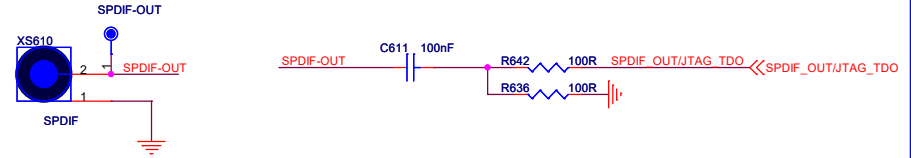

EARPHONE

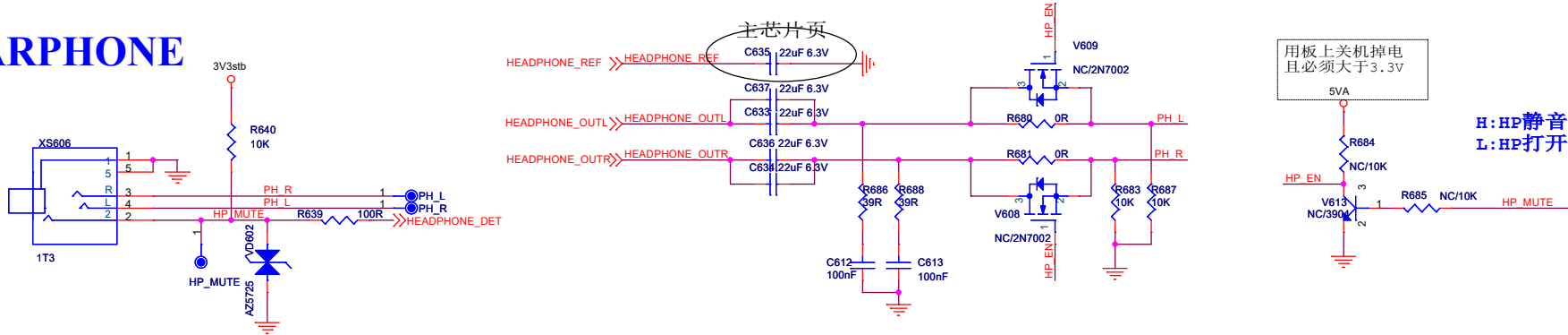

					拟制		08. Video
					审核		
标记	数量	更改单号	签名	日期			第 8 张

USB

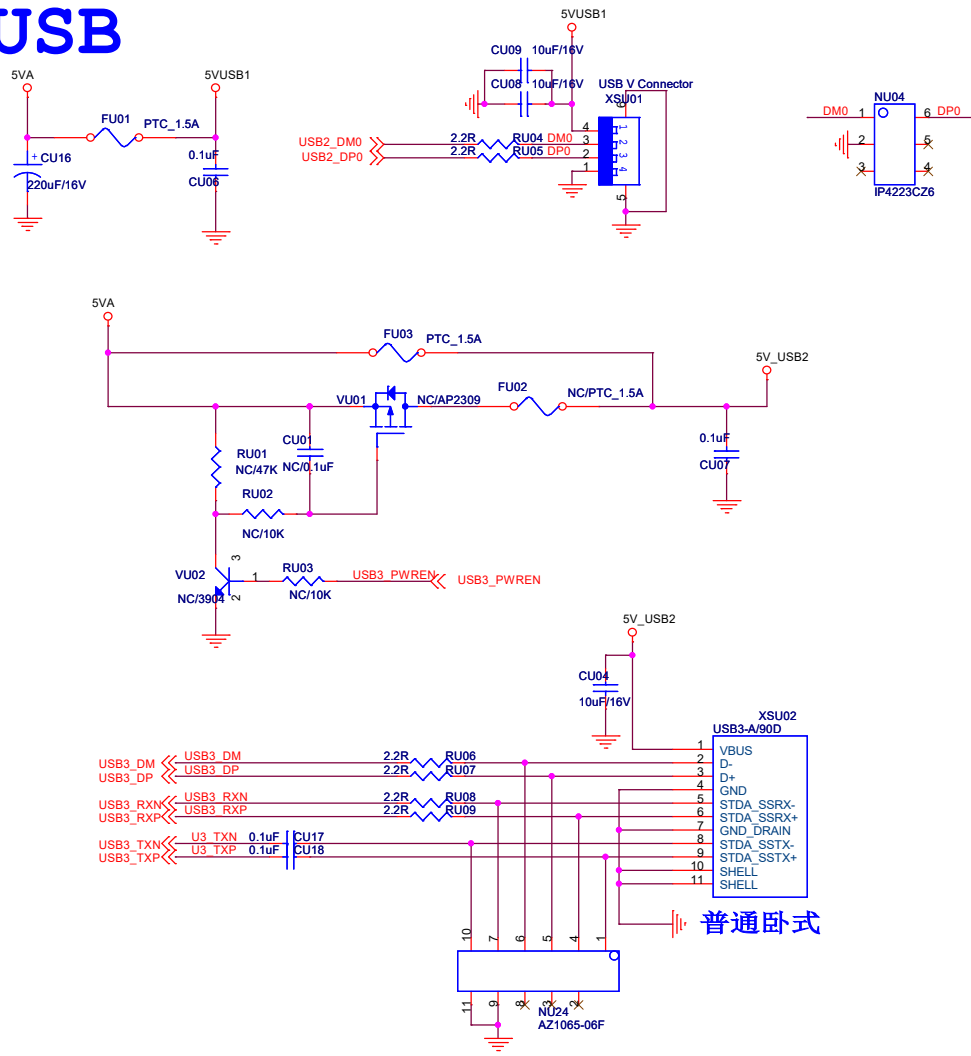

Ethernet

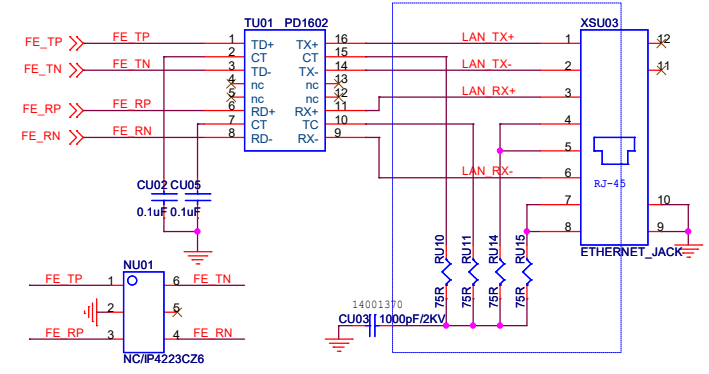

WIFI ON BOARD

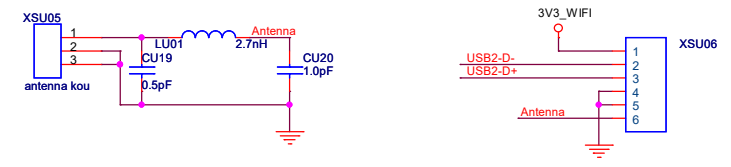

WIFI 蓝牙

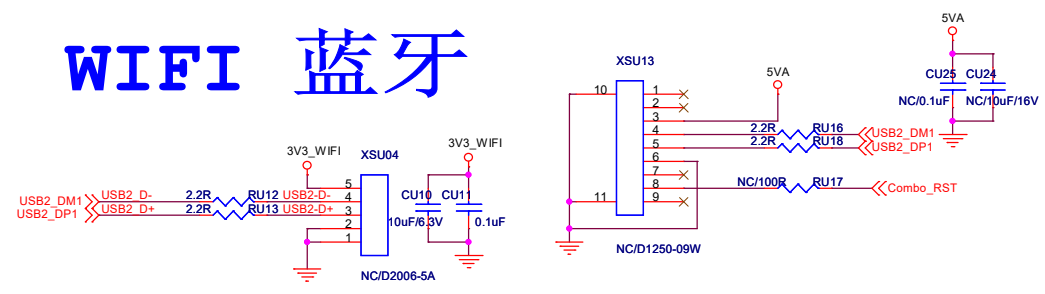

					拟制	
					审核	
标记	数量	更改单号	签名	日期		

09. USB&Ethernet

HDMI 0

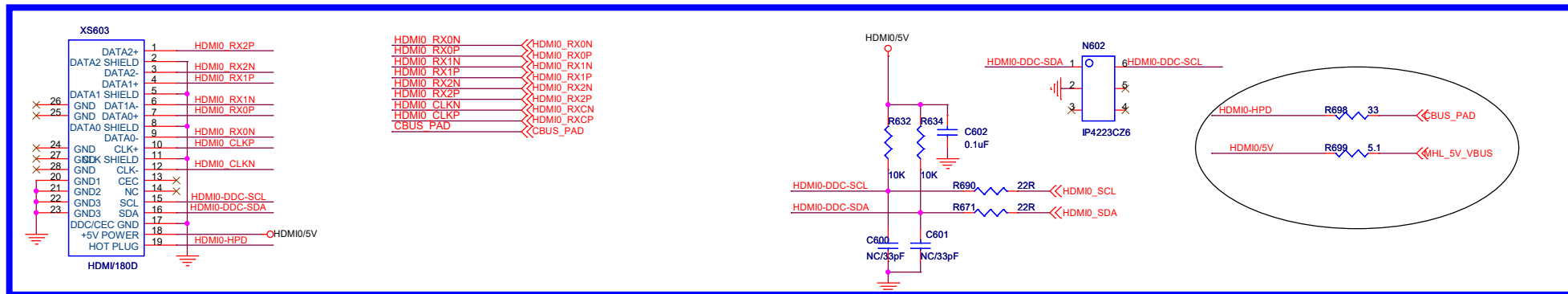

HDMI 1

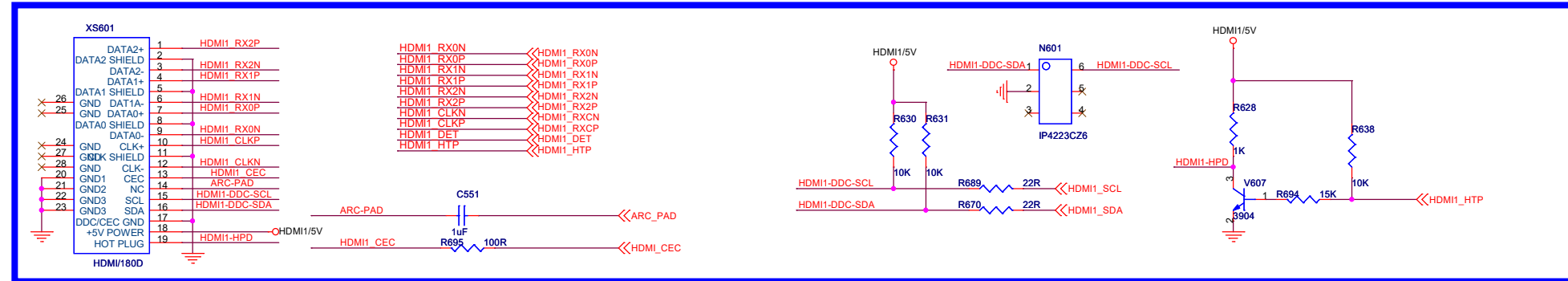

HDMI DETECT

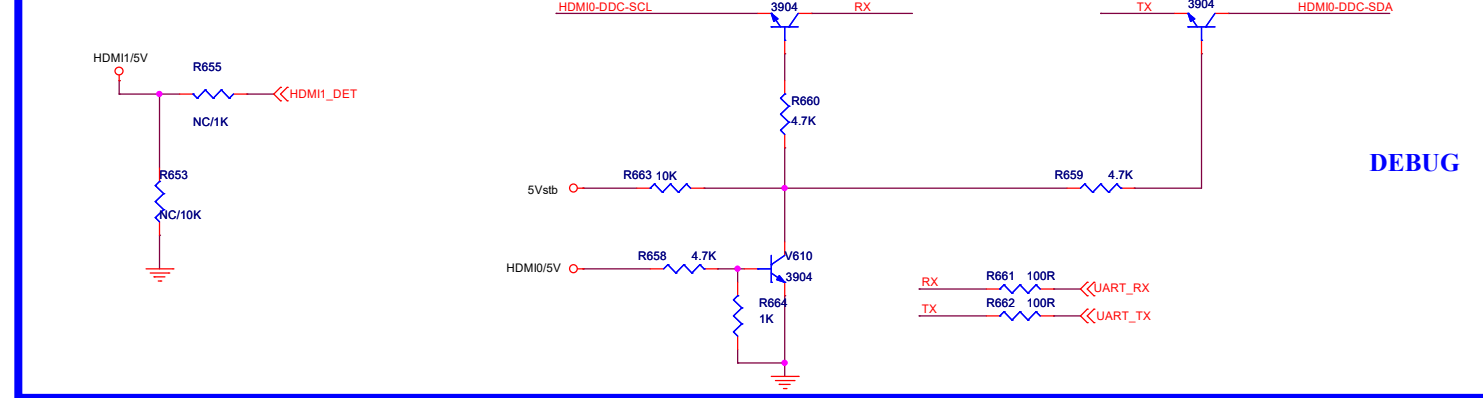

						拟制	
						审核	
标记	数量	更改单号	签名	日期			
							10. HDMI
							第 10 张

TUNER

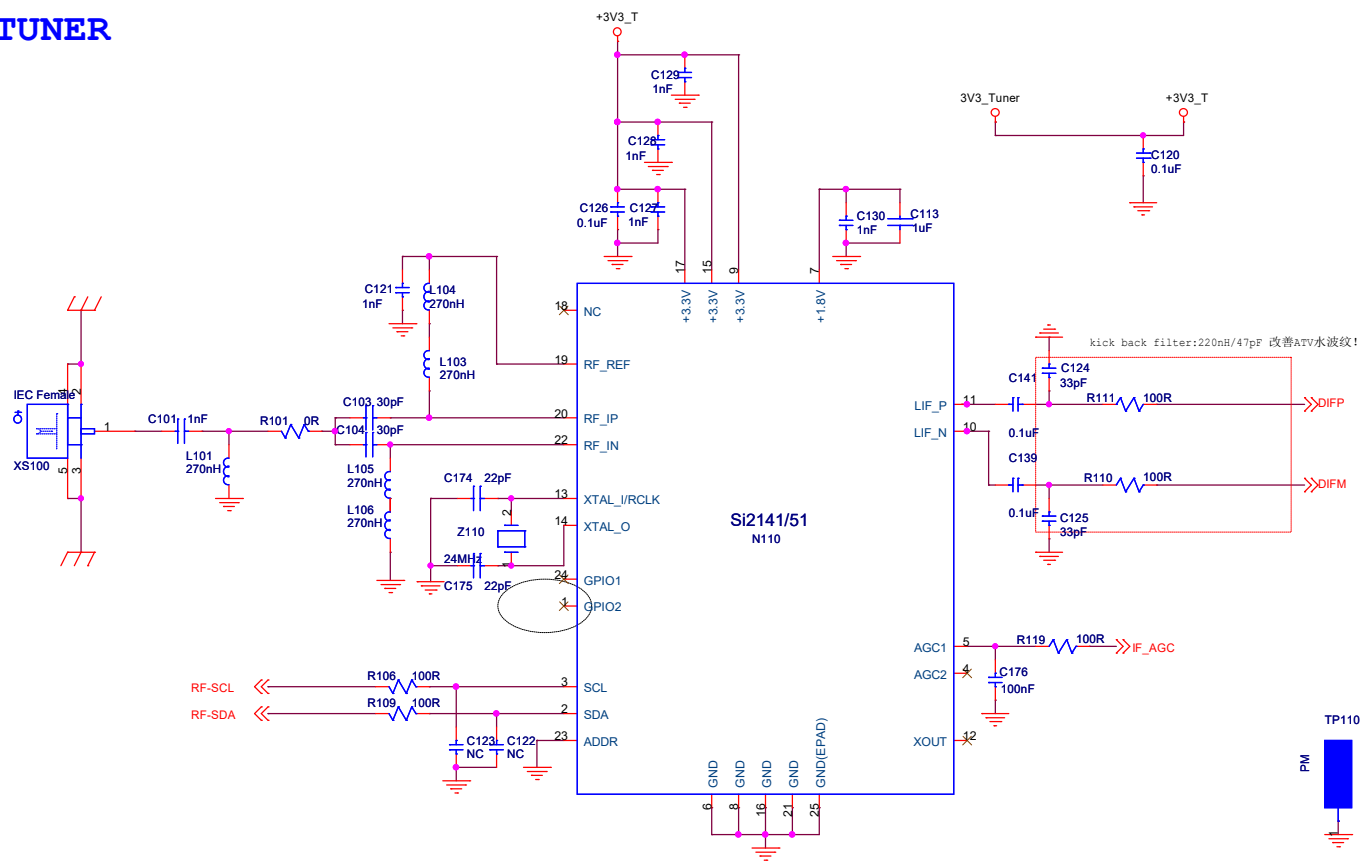

内置隔离

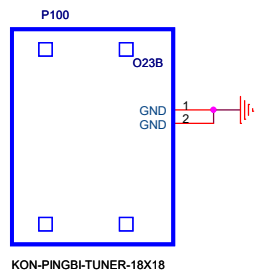

背面预留隔离电容

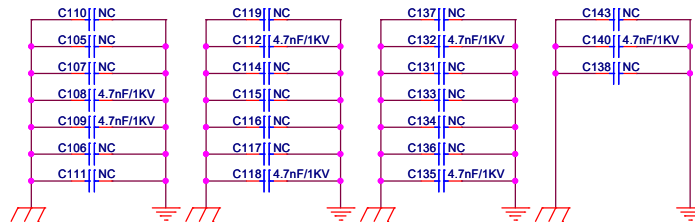

					拟制		11. Tuner
					审核		
标记数量	更改单号	签名	日期				第 11 张

